

## Series Spec Sheet

# S3NV

## THREE PHASE INVERTER

### Big, Powerful Inverter System

Centralized emergency lighting inverters featuring one of the smallest pure sine wave three phase cabinet footprints in the industry.

#### APPLICATIONS

- Industrial Manufacturing
- Warehouses
- Theaters/Concert Halls
- Auditoriums
- Conference/Banquet Centers
- Shopping Malls
- Casinos
- Sports Facilities
- University Buildings
- Healthcare Facilities
- Subway/Train Stations
- Correctional Facilities
- Worship Facilities



#### COMPLIANCES

- UL 924 Listed
- c-UL Listed to CSA C22.2
- NFPA 101, 111, NEC, IBC

	Output Rating (kW)	Width (in)	Depth (in)	Height (in)
<b>S3NV</b>	33	70	33	77
<b>Competitor A</b>	32	130	32.5	71
<b>Competitor B</b>	33	140	31	72

Note: Dimensions include 90 minutes of battery at full load.

**EMERGENCY LIGHTING REQUIREMENTS**

Stanpro meets stringent requirements in construction, performance, self-diagnostic and self-testing of S3NV centralized emergency lighting inverter. S3NV is UL 924 listed as “Emergency Lighting Equipment” and “Auxiliary Lighting and Power Equipment”, as well as NFPA compliant as “Life Safety Equipment”. The S3NV offers more security and versatility to meet illumination requirements, being the perfect complement for all life safety and lighting applications.

Our inverter technology effectively maintains critical equipment with extended brownout protection, tight voltage regulation, and power conditioning. Tight voltage regulation assures that facility egress lumens are maintained 100% at emergency lighting fixtures, in all modes of operation, and also extends ballast, LED driver, and lamp life.

**• Advantages**

**Design Flexibility**

Using existing fixtures for emergency lighting and egress assures compliance with minimum illumination code requirements. Extensive combinations of input and output voltages, timed off bus with remote “Command ON” control, automatic battery testing, and control device override options make the S3NV one of the most versatile and dependable lighting inverter systems in the market.

**Single Point Operation / Maintenance**

One central inverter controls many smaller circuits. Cost-effective, single-point operation, provides a common battery pack, and enables all maintenance to be performed and records to be logged from a single location. Additional benefits include :

- Egress lighting integrity test.
- Hot-swappable battery replacement.
- Standard internal bypass.
- Standard 15-year pro-rated battery life.

**Premium Power And Voltage Regulation**

Maintains proper operating voltage for HID and high-pressure sodium lighting, as well as electronic ballasts and LED lighting, resulting in :

- Voltage sag and surge protection.
- Longer wire runs without upsizing the wire.

Regulated voltage source minimizes voltage drop.

- Less-frequent replacement of ballasts, LED drivers, and lamps.
- Facility egress lumens are maintained 100% (will not diminish) over the full 90 minute of emergency power.

**Generator Compatible**

The S3NV is listed “UL 924 Auxiliary Lighting and Power Equipment”, and is suitable to provide uninterrupted back-up power until a generator starts. Even with an extremely distorted input waveform, the output of the S3NV delivers a clean sine wave, with no more than 3% THD, without switching to batteries. This feature also extends ballast, LED driver, and lamp life.

**ADVANCED DIGITAL MONITORING**

**• Alarms & Status**

- The Intellistat TS announces multiple alarms, including :
- Input phase rotation error
  - System on battery
  - High/low input voltage
  - Low battery warning
  - High/low input frequency
  - Low battery shutdown
  - High/Low output voltage
  - Battery test in progress
  - High/Low output frequency/time remaining
  - High output VA (overload)
  - Auto battery test failed
  - Low output VA <sup>1</sup>
  - OFF bus status
  - High/Low battery voltage
  - DC charger fail/DC open
  - High battery charger current
  - Output circuit breaker open
  - System normal
  - REPO shutdown
  - IGBT fault
  - Manual restart required
  - Overtemp shutdown
  - Static bypass status/alarms
  - System in manual bypass

**• Monitored Parameters**

- The Intellistat TS monitors 3-phase input and output parameters, and inverter status indicators :
- Voltage
  - kVA and kW totals
  - Frequency
  - Output percent load L-N (% kVA)
  - Current
  - Output percent load total (% kVA)
  - VA
  - Battery voltage
  - Watts
  - Battery charge/discharge current
  - Power factor
  - Battery time (minutes) remaining

**• Communication**

Touchscreen display for on-sight monitoring. Network capacity for remote access, monitoring, reporting & notification.

A newer simple method for providing remote BAS network signals is available at a very low cost and covers all signal types.

Having important Inverter status or alarm notifications to any workstation is quick and convenient.

**• Egress Lighting Integrity Test**

This feature provides the industry’s most advanced life safety system test available. To satisfy NFPA-mandated periodic and annual requirements, the Intellistat TS automatically initiates the testing of all life safety circuits, regardless of egress lighting design (“always ON” or “normally OFF”). The Intellistat TS then compares power consumption during the test period with user-defined load capacity, analyzing the data, and advising if service is required.

**• Automatic System Tests**

The Intellistat TS automatically performs a user-defined (date and time) 5-minute system test every 30 or 90 days. It also performs user-defined (date and time) 30-, 60-, or 90-minute, or 2- or 4-hour annual system tests. For all of these tests, the Intellistat TS logs the test results with date and time, as well as a “pass” or “fail” indication.

**• Manual System Tests**

The Intellistat TS also allows the user to manually invoke a user-defined system test for 30-, 60-, or 90-minutes, as well as 2- or 4-hours. A 1-minute or 5-minute manual test is also available for “spot inspections”.

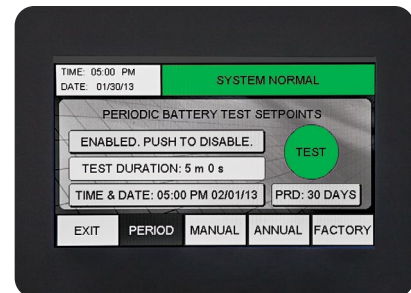

Note: The color touchscreen display on the Intellistat TS provides all electrical parameters, inverter status, programmable inverter, battery testing, and data-logging. Optional NetMinder™ communications allow remote monitoring and reporting via BACnet/IP or BACnet MS/TP, Ethernet TCP/IP, MODBUS TCP, or MODBUS RS485.

<sup>1</sup> User-programmable limit referenced during automatic battery testing, to verify integrity of egress lighting.

**Data is based upon tests performed in a controlled environment. Actual performance can vary depending on operating conditions. All products are subject to change or may be discontinued any time without notice.**

**SPECIFICATIONS**

**POWER**

Ratings (kVA/kW)	10, 13, 14, 15, 16, 17, 20, 22, 24, 26, 28, 30, 32, 33, 40, 45, 50, 55 at 1.0 (unity) power factor
Topology	True online double-conversion, uninterruptible power

**ELECTRICAL INPUT**

Nominal Voltage	60 Hz : 208/120 V, 480/277 V or 600/347 V Wye. Consult factory for 50 Hz models.
Voltage Range	+10%, -15% at full load
Operating Frequency	+/-5% from nominal
Power Factor	> 0.98 typical
Current Distortion	< 10% THD
System AIC Rating	10k AIC standard; 65k or 100k AIC optional

**ELECTRICAL OUTPUT**

Nominal Voltage	60 Hz : 208/120 V, 480/277 V or 600/347 V Wye. Consult factory for 50 Hz models.
Voltage Regulation	+/-3% from nominal typical
Frequency	+/-0.5% while in battery operation mode
Overload	Up to 110% for 2 minutes, 125% for 30 seconds, 150% for 10 seconds, 400% for 4 cycles (without use of static bypass)
LED Inrush Rating	Peak overload capability of 1700% to accommodate inrush current from LED fixtures (without use of static bypass and in battery mode)
Efficiency	90% typical

**BATTERY**

Type	Valve-regulated, sealed lead calcium, maintenance-free. Front access terminals
Testing	Manual : Password-protected Automatic : User-programmable
Standard Runtimes	UL 924 Emergency Lighting Equipment - 90 min. & C-UL Emergency Lighting Equipment - 30 min.
Optional Runtimes	UL 924 Auxiliary Lighting and Power Equipment - 15, 30, 60, 120, and 240 minutes. Consult factory for other UL / C-UL listed runtimes.
Nominal Voltage	Factory-programmable from 216-408 VDC, or from 132-168 VDC, kW, model, and runtime dependent
Charger	3-stage, temperature compensated
Recharge Time	UL 924 and NFPA 101, 111 compliant
Battery Replacement	Hot-swappable batteries - replaced without interrupting power to the load

**UL RATING TEMPERATURE TEST COMPARISON<sup>1</sup>**

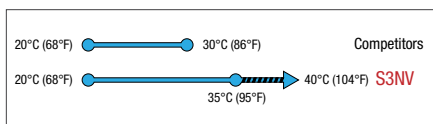

<sup>1</sup> To satisfy UL 924 requirements for a 35°C rating, UL testing was performed in a 40°C ambient environment, with units tested under full load and at low line input voltage.

<sup>2</sup> Monitored output circuit breaker standard on C-UL listed models, optional on UL 924 listed models.

Note - illustration : The callouts above reflect standard features. Protective Inner Panel in the Inverter Cabinet Allows Operation of Breakers & Bypass, But Prevents Physical Contact with Live Connections.

Data is based upon tests performed in a controlled environment. Actual performance can vary depending on operating conditions. All products are subject to change or may be discontinued any time without notice.

**GENERAL**

Diagnostics	Continuous system self-check, including battery health
Static Bypass	Automatic bypass on overload or system failure
Internal Bypass	Integral, make-before-break switch with a secure push-to-turn function that provides an uninterrupted bypass of the inverter system
External Maintenance Bypass	Wrap-around, 4 pole BBM or MBB switch with a secure push-to-turn function, available for models where input-output nominal voltages are the same
Remote Emergency Power Off (REPO)	Optional input relay interface allows external contact closure to shut off the inverter system
Normally Off Bus	Optional standby output for use with "normally off" emergency lighting fixtures
Output Distribution	Optional output circuit breakers (see page 4 for details)
Miscellaneous	Drip Shield is standard Form C is standard

**CERTIFICATIONS**

Safety	UL 924 Listed - Emergency Lighting Equipment C-UL Listed to CSA C22.2 No. 141-15 - Emergency Lighting Equipment UL 924 Listed - Auxiliary Lighting and Power Equipment NFPA 101, 111, NEC, and local codes
EMI Compliance	FCC Class A limits, 47 C.F.R. Part 15, Subparts A, B
Quality	ISO 9001:2015

**COMMUNICATIONS**

LCD Display	High resolution, color touchscreen display for monitoring system status and parameters, and to access programmable inverter and battery testing
Communication Port	RS232 serial communications for factory setup and authorized field service access
Network / Web	Remote monitoring and reporting via optional BACnet/IP or BACnet MS/TP, Ethernet TCP/IP, MODBUS TCP, or MODBUS RS485. Includes notification of alarms via SNMP, e-mail, and network broadcast messaging, or user's building management system
Relay Interface	Optional potential-free isolated status and alarm contacts via hardwired terminal strip. Contacts rated for 2 A at 30 VDC, or 1 A at 120 VAC

**ENVIRONMENTAL**

Operating Temperature	- 20°C to 35°C for UL 924 Listed models (See illustration and note below) - 20°C (10° C optional) to 40° C for C-UL Listed models - Optimum battery performance and life at 25°C
Storage Temperature	Inverter at -20°C to 50°C Battery storage at 25°C for 6 months before charging is required. For each 9°C rise, reduce storage time by half.
Relative Humidity	0 to 95% non-condensing
Audible Noise	< 60 dBA at 1 meter
Altitude	6 600' (2 000 m) without derating

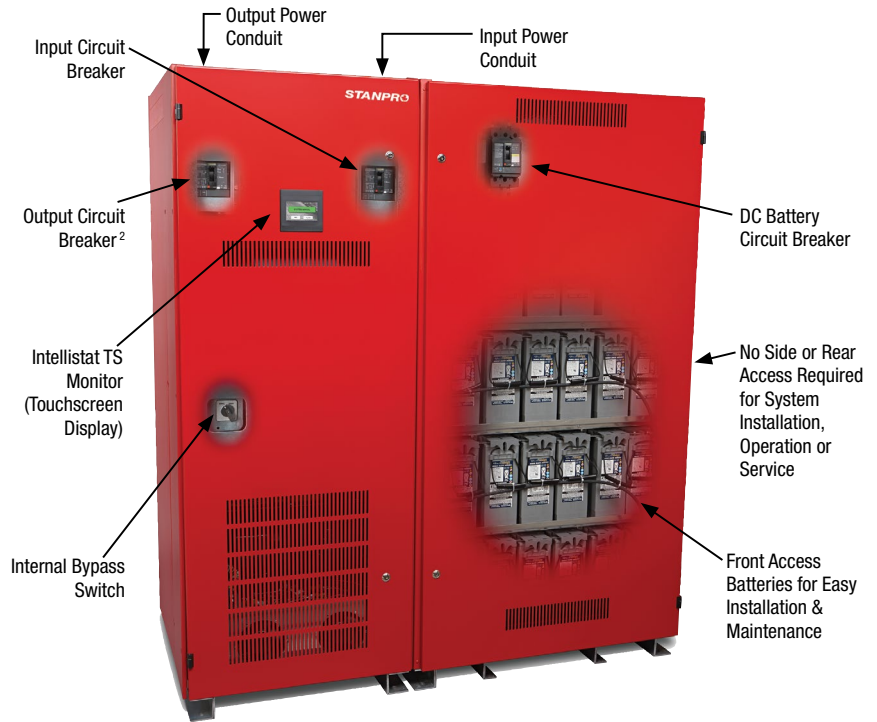

## INVERTER OPTIONS

### • Battery Run Times

All UL 924 models listed as Emergency Lighting Equipment are provided with a standard 90 minute of battery backup. C-UL models are provided with a standard 30 minutes backup. Please consult factory for other C-UL listed run times. Optional run times include 15, 30, 60, 120, and 240 minutes at full rated load. When optional run times are provided, the emergency lighting inverter is UL 924 listed as "Auxiliary Lighting and Power Equipment". Please consult factory for battery option weights and cabinet configurations.

### • External Maintenance Bypass

On systems in which the nominal input and output voltages are the same and without a normally OFF option or distribution breakers, an optional external, wall-mounted, push-to-turn, 4 pole Break-Before-Make (BBM) or Make-Before-Break (MBB) wrap around maintenance bypass switch is available. In bypass mode, the switch bypasses the system allowing isolation of the inverter's input and output, and to enable the inverter to be fully serviced (including the complete maintenance and replacement of circuit cards or components). The bypass switch includes an auxiliary contact to indicate the position of the switch (normal or bypass) for remote monitoring purposes.

The MBB bypass switch has a second auxiliary contact which is wired to the inverter system. This contact enables the switch's push-to-turn function to invoke the static bypass before the switch is turned to the bypass position. With the static bypass engaged, no interruption of power to the load will occur during transfers and retransfers.

### • Integral Maintenance Bypass

This integral, push-to-turn, 4 pole Make-Before-Break (MBB), wrap-around maintenance bypass switch option is physically located within the Distribution Cabinet, and may be used with any available voltage configuration. This switch bypasses/isolates the 480/277 VAC inverter section (cabinet), and is provided with a padlock attachment for lockout/tagout purposes during maintenance. The switch also includes an auxiliary contact to indicate the position of the switch (normal or bypass) for local or remote monitoring purposes.

### • Output Distribution Models 10 kW to 33 kW

Provided in a side-mounted, 14" wide, front access distribution cabinet, a total of 12 pole positions per phase (36 total) are available to accommodate 1, 2, and 3 pole circuit breakers fed from an inverter system output of 208/120 VAC or 480/277 VAC. These circuit breakers are located behind a secured, lockable, hinged door; and can be factory-wired to the "Normally ON" bus and/or "Normally OFF" bus in any combination specified.

Monitored output circuit breakers are available, reducing the number of pole positions to 8 per phase (24 total). If a circuit breaker is open, the Intellistat TS monitor sounds an alarm. Optional alarm relay contacts are also available.

### • Output Distribution Models 40 kW to 55 kW

Systems are available with a front access distribution cabinet containing a main input circuit breaker, and up to four factory-installed 3-pole output circuit breakers, amperage-rating dependent. All breakers are located behind a secured, lockable, hinged door; and output breakers can be wired to the "Normally On" bus and/or "Normally Off" bus in any combination specified.

Monitored output circuit breakers may be specified, without reducing the number of breakers available. If a circuit breaker is open, the Intellistat TS monitor sounds an alarm. Optional alarm relay contacts are also available.

### • Normally OFF Bus

Provides standby power to "normally OFF" emergency lights when utility power is lost or inadequate, or if energized via a remote alarm contact. Solid state operation with current limiting feature designed to have a longer life than a relay, and rated at 100% of the systems power. This option includes:

#### User-Programmable Settings

Transfer On Delay (0 – 8 seconds)

Transfer Off Delay (0 – 15 minutes)

#### Remote Input "Command ON"

Allows a remote alarm contact signal to energize the "Normally OFF" bus, thus illuminating the "Normally OFF" emergency lights.

### • Status/Alarm Relay Contacts

Isolated, potential free (Form C) relay contacts, rated for 2 A at 30 VDC or 1 A 120 VAC, are available via a terminal strip for customers' hardwired connections to building monitoring and security systems. Status/alarm contacts include inverter ON, ON battery power, low battery, general alarm, in bypass, periodic or annual test activated, output circuit breaker open, battery test pass, and battery test fail.

### • Remote Communications

The S3NV's Intellistat TS monitor is available with optional NetMinder communications. NetMinder integrates the S3NV into a BACnet/IP or BACnet MS/TP, Ethernet TCP/IP, MODBUS TCP, or MODBUS RS485 network with a specific IP address for Ethernet connected systems. NetMinder provides remote monitoring of the inverter status, battery test pass/fail results, alarm conditions, and electrical measurements via a web browser, without the need for any external software. Remote notification of alarms and status are available via SNMP, e-mail, and network broadcast messaging, or the user's building management system.

Note : Only 4 sub-main output breakers available on 40-55 kW models.

Data is based upon tests performed in a controlled environment. Actual performance can vary depending on operating conditions. All products are subject to change or may be discontinued any time without notice.

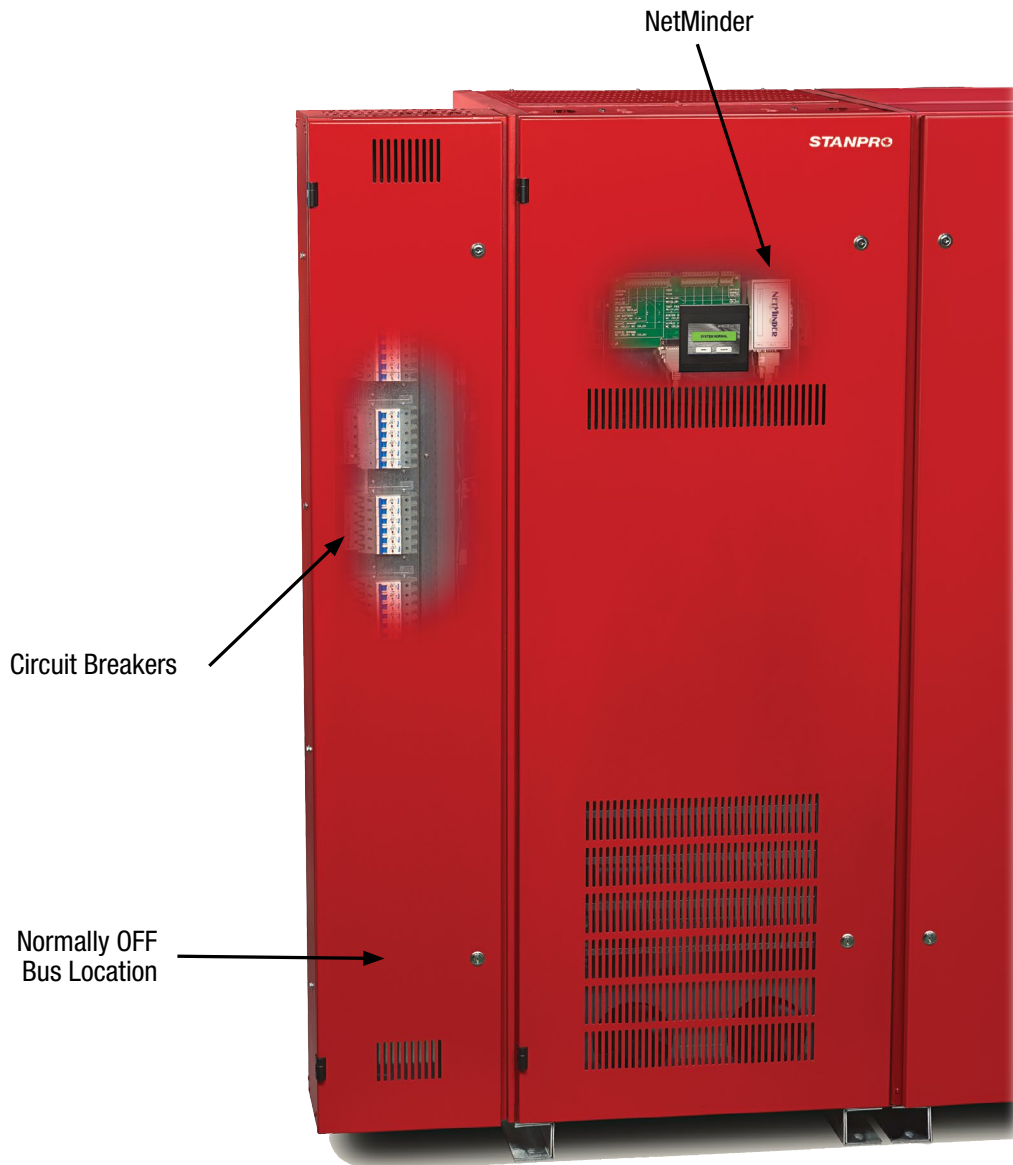

Data is based upon tests performed in a controlled environment. Actual performance can vary depending on operating conditions. All products are subject to change or may be discontinued any time without notice.

**ORDERING GUIDE**

Series runtime (minutes)	Input Voltage (VAC)	Capacity Rating (kW)		Output Voltage (VAC)	Monitor	Output Distribution <sup>1</sup>	Relay interface options	Options
S3NV30	BA - 208/120	10	26	BA - 208/120	0 - Intellistat	0 - Intergral main CB Only	0 - None provided	A - 65k AIC Rating for the Inverter Input
S3NV60	KE - 480/277	13	28	KE - 480/277	1 - Intellistat with:	1 - Distribution Cabinet	1 - Output Alarm relay	B - External Maintenance Bypass (EMBP)
S3NV90	SH - 600/347	14	30	SH - 600/347	· TCP/IP	2 - Distribution Cabinet w/ Normally OFF bus	2 - Off bus "Command ON" and REPO Inputs	C - Remote Alarm Annunciator Panel
S3NV120		15	32		· Modbus TCP	3 - Monitored Output Circuit Breaker (MOCB)		D - Seismic Rated (for units up to 33 kW only)
		16	33		· Modbus RS485			
		17	40		· BACnet/IP			
		20	45		· BACnet MS/TP			
		22	50					
		24	55					

<sup>1</sup> Please consult factory rep for available configuration.

**BTU**

KVA/KW	"BTU/HOUR FULL LOAD"
10	3 410
13	4 433
14	4 774
15	5 115
16	5 456
17	5 797
20	6 820
22	7 502
24	8 184
26	8 866
28	9 548
30	10 230
32	10 912
33	11 253
40	19 086
45	21 483
50	23 870
55	26 257

**VOLTAGE CONFIGURATIONS**

INPUT OUTPUT VAC 60 HZ	Input	Output
BABA	208/120	208/120
KEBA	480/277	
SHBA	600/347	
BAKE	208/120	480/277
KEKE	480/277	
SHKE	600/347	
BASH	208/120	600/347
KESH	480/277	
SHSH	600/347	

Stated full load BTU's for 480/277 VAC input – output models. Consult factory for BTU's of other models.

**TYPICAL INVERTER 3 PHASE SCHEMATIC**

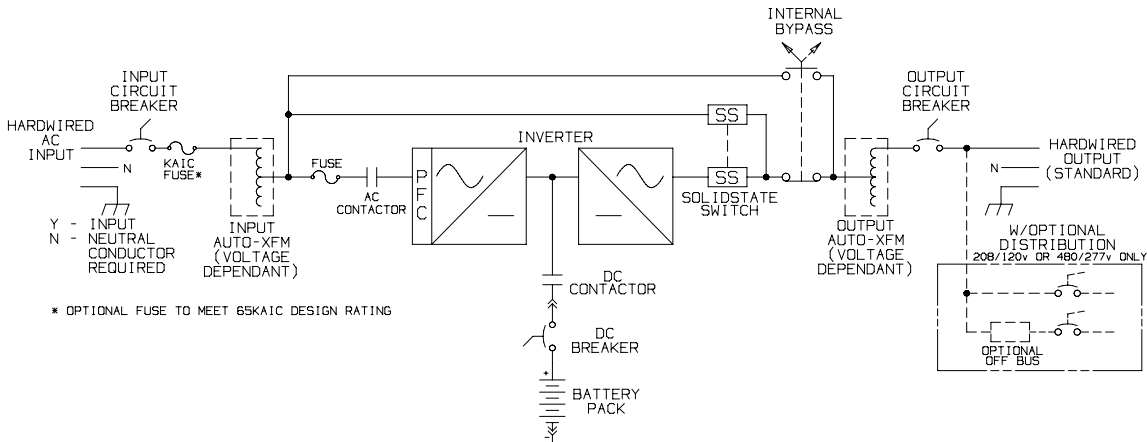

Note: Contact Stanpro for single line drawing that include the external bypass switch

Data is based upon tests performed in a controlled environment. Actual performance can vary depending on operating conditions. All products are subject to change or may be discontinued any time without notice.