

Series Spec Sheet

DSL-L

DUAL HEAD LED SECURITY LIGHT

3 CCT Selectable

INTEGRATED MOTION SENSOR

Our DSL series features a built-in dusk to dawn sensor which allows to turn on the lights at dusk and turn off the light at dawn and a motion sensor that allows setting the lights to turn ON when motion is detected. These features assures the area is well lit and provides added security at night. Offering superior performance while improving on energy savings, this fixture is ideal for walkways, yards, driveways, patios, parking lots and loading docks.

FEATURES AND SPECIFICATIONS

• Construction

Physical Characteristics

- This luminaire is made of aluminum die cast housing and comes standard in a Bronze or White powder coat finish
- Dual Adjustable heads
- Frosted Glass Lens
- CCT switch is placed discretely inside the housing
- Built-in dusk to dawn feature

Mounting

- Wall/Surface Mounting
- Adjustable Arm for precise positioning of the motion sensor

• Performance data

- Available 3 000/4 000/5 000 K selectable color temperature
- 80+ CRI
- Electrical ratings: 120V
- Estimated life of over 100 000 hours to L70
- Operating temperature:
-40 °C to 50°C (-40 °F to 122 °F)

• Compliances

- cETLus listed for wet locations
- Meets requirements of ICES-005 issue 5 for class B products
- IP65



OVERVIEW

Light source	LED
Watts (W)	20
Lumen output (lm)	1712 - 1974
Efficacy (lm/W)	86 - 99
Color temperature (K)	3 000/4 000/5 000
CRI	80+



quick
ship



LED
fixture

6⁶

wet
location



QUICK SHIP AND TECHNICAL SPECIFICATION TABLE

Order code	Model number	Watts (W)	Volts (VAC)	Color temp. (K) ¹	Lumen output (lm) ^{2,3}	Efficacy (lm/W)	CRI	Life L70 (hrs) ⁴	Tested hours LM-80 (hrs) ⁴	Calculated TM21 (hrs) ⁴	Beam angle (°)	BUG	LED current (mA)	Finish	Dimming	Power factor	THD (%)	Traditional equivalent (W)	Master case qty
																		MH	HPS

CCT Selectable

69236	DSL-LS1A-A-3C-BR	20	120	3 000/4 000/5 000	1 974	86 - 99	80+	>100 000	10 000	>60 000	50	B2-U1-G0	0.18	Bronze	No	>0.9	<20	2x100	2x60-75	5
69237	DSL-LS1A-A-3C-WH	20	120	3 000/4 000/5 000	1 974	86 - 99	80+	>100 000	10 000	>60 000	50	B2-U1-G0	0.18	White	No	>0.9	<20	2x100	2x60-75	5

¹ Typical color temperature range: +/- 5 %.

² Lumen values are derived from photometric testing. Initial lumens range: +/- 10 %.

³ Lumen values are based on 4 000 K default programming. Please refer to the LUMEN SPECIFICATION TABLE for more details on other color temperatures.

⁴ Life hours are derived from IESNA LM-80-08 testing report and projected per IESNA TM-21-11 extrapolations.

LUMEN SPECIFICATION TABLE

Order code	Model number	Watts (W)	3 000 K			4 000 K			5 000 K		
			Lumen output (lm)	Efficacy (lm/W)	LED Current (mA)	Lumen output (lm)	Efficacy (lm/W)	LED Current (mA)	Lumen output (lm)	Efficacy (lm/W)	LED Current (mA)
69236	DSL-LS1A-A-3C-BR	20	1712	86	0.18	1974	99	0.18	1809	90	0.18
69237	DSL-LS1A-A-3C-WH										

DEFAULT PROGRAMMING

69236, 69237 : 4 000 K

ON/OFF SENSORS

Position	Volts (V)	Technology	Height (ft max)	Detection Range (ft)	Detection Area(°)	Hold time (min)	Location (°C)
External	120	High Frequency	7.2 ft	10 up to 60	180 horizontal	1 to 10 min	Dry and wet, -40°C to 40°C
					45 vertical		

¹ Please see the instruction sheet to deactivate the motion sensor.

MOTION SENSOR

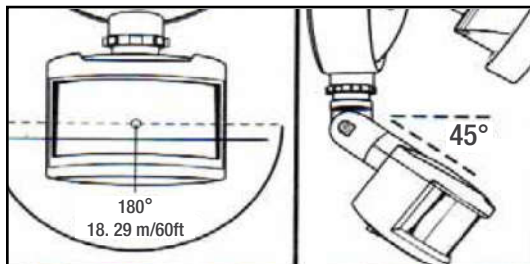

Data is based upon tests performed in a controlled environment. Actual performance can vary depending on operating conditions. All products are subject to change or may be discontinued any time without notice. Please contact your Stanpro customer service representative to confirm inventory levels at time of order.

DIMENSIONS AND WEIGHTS

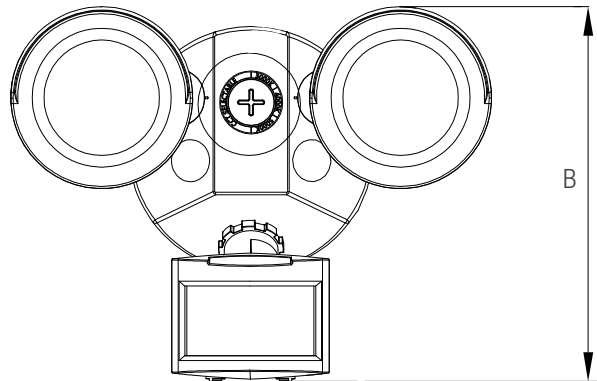
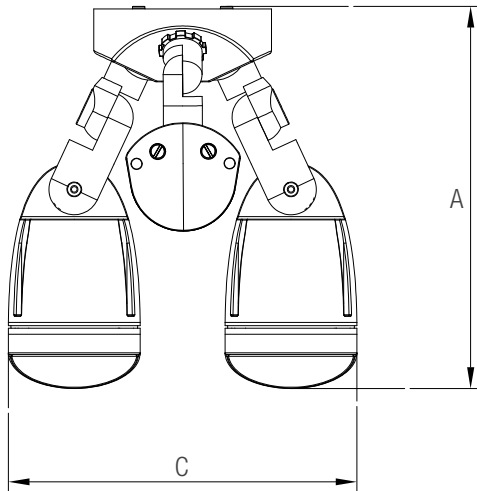

A in. (cm)	9 (22.86)
B in. (cm)	6 (15.24)
C in. (cm)	8 (20.32)
Net weight (lbs)	0.3

PHOTOMETRIC DATA¹

69236_69237 • DSL-LS1A-A-3C-XX • 10W • 4000K • 983lm (single head)

Polar candela distribution

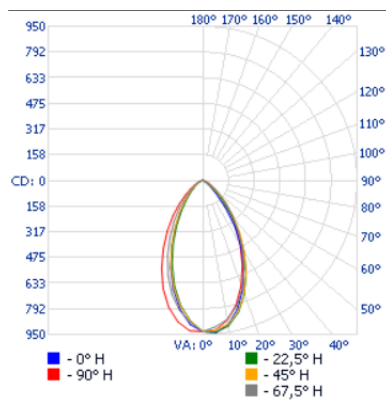

Zonal lumen summary

Zone	Lumens	% Luminaire
0-30	551.5	56.1
0-40	757.5	77
0-60	945.2	96.1
60-90	36.5	3.7
70-100	10.7	1.1
90-120	0.4	0
0-90	981.7	99.8
90-180	1.5	0.2
0-180	983.2	100

Illuminance at a distance

Center beam fc		Beam width	
17'	3.23	17.4'	19.6'
34'	0.81	34.9'	39.2'
51'	0.36	52.3'	58.8'
68'	0.20	69.8'	78.5'
85'	0.13	87.2'	98.1'
102'	0.09	104.7'	117.7'

■ Vert. spread : 54.3°
■ Horiz. spread : 60.0°

¹ Complete IES files available on our website.

Data is based upon tests performed in a controlled environment. Actual performance can vary depending on operating conditions. All products are subject to change or may be discontinued any time without notice. Please contact your Stanpro customer service representative to confirm inventory levels at time of order.